

Data sheet

KNX BAOS Module 838 kBerry

KNX Module for Raspberry Pi

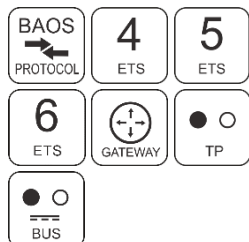

(Art. # 5208)

Application area

The KNX BAOS Module 838 kBerry is an extension board for the Raspberry Pi® single-board computer. It can be plugged directly on the Raspberry board and serves as a serial interface to KNX. BAOS stands for "Bus Access and Object Server". So the module allows the access to the KNX bus on telegram level (KNX Link Layer) as well as on data point level (KNX Application Layer). The connection between application and KNX BAOS Module is established via a UART connection (FT1.2 framing).

For a quick start a generic ETS® entry with 1000 group objects is available. Individual ETS entries can be created as well. The KNX BAOS Module 838 is powered via the bus and provides galvanic isolation. The firmware of the KNX BAOS Module 838 is fully compatible with the KNX BAOS Module 830.

Technical Specification

Electrical safety

- Safety extra low voltage SELV DC 29 V

Compliant with

- RoHS directive 2011 / 65 / EU
- EN 63000: 2018

Environmental requirements

- Ambient temp. operating: - 5 ... + 45 °C
- Ambient temp. non-op.: - 25 ... + 70 °C
- Rel. humidity (non-condensing): 5 ... 93 %

Mechanical data

- Dimensions (L x W): 56 x 35 mm
- Height: 8 mm (without conn.), Board: 1.5 mm
- Weight: approx. 12 g

Power supply

- From KNX bus, current consumption 3 mA
- From Raspberry 3.3 V DC for isolated UART

Connectors

- KNX connector red/black
- Host connector 26-pin female

User Interface

- LED and Key for KNX programming mode
- Status LEDs for power, KNX and host connection

Host Interface

- Baud rate 19.2 / 115 kBit/s, 8e1
- Serial frame format FT1.2
- KNX telegram format: common EMI (cEMI)
- BAOS Protocol V2

KNX

- Certified KNX Stack (System B)
- Long frames, max. APDU length 55
- Up to 1000 group objects
- Up to 70 kByte parameter space

Documentation and Source Code

Documentation and sources are mainly for the KNX BAOS Starter Kit (830, 832 Modules), but the sources can be used as reference for an own application.

The complete KNX BAOS Starter Kit documentation, the ETS databases, the source code of the demo application and a free SDK (Software development kit) for Raspian can be found on our BAOS and 838 kBerry download page at: <http://www.weinzierl.de>

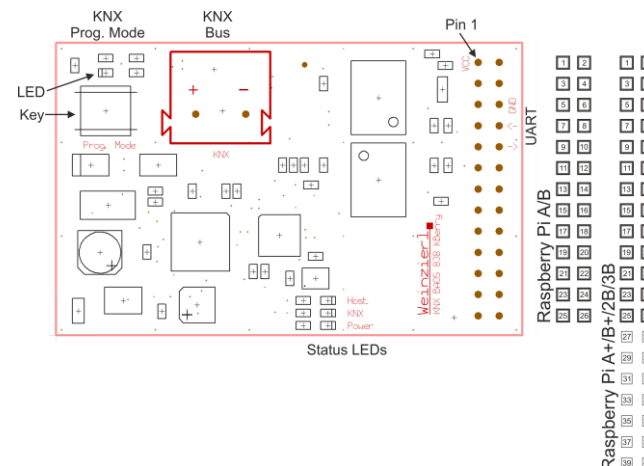
PIN assignment

- KNX Bus -
- KNX Bus +
- Host interface pin 1: VCC
- Host interface pin 6: GND
- Host interface pin 8: RX (to 838)
- Host interface pin 10: TX (from 838)

ETS6 Datenbank
www.weinzierl.de/de/products/838/ets6

WEINZIERL ENGINEERING GmbH
 Achatz 3-4
 84508 Burgkirchen an der Alz
 GERMANY

Tel.: +49 8677 / 916 36 - 0
 E-Mail: info@weinzierl.de
 Web: www.weinzierl.de

